



Sa vz. 58 Bolt Action

cal. 5.56 x 45 mm

cal. .222 Remington

cal. 7.62 × 39 mm

Instructions Manual



WARNING!
READ THE INSTRUCTIONS IN THIS MANUAL
BEFORE USING THIS FIREARM.

Safety Instructions

WARNING!

1. Carefully read the instructions and warnings in this Instruction Manual before using this firearm. Failure to follow the instructions in this Manual could result in the following: death or serious bodily injury to the operator, death or serious bodily injury to others, and damage to property.
2. In addition to studying and thoroughly understanding this Manual, ensure safety training is received from a competent firearms instructor before handling or using this firearm. Czech Small Arms, s.r.o. shall not be liable for any injury to persons or any damage to property resulting from the use of this firearm.
3. This Instruction Manual must accompany the firearm at all times and be transferred with the firearm in the event of a change in ownership, or when the firearm is loaned or presented to another person.
4. Always ensure the firearm and ammunition is kept away from children and unauthorized persons by keeping them locked up. SAFETY IS YOUR RESPONSIBILITY AT ALL TIMES!

CAUTION!

Ensure the following safe firearm handling is observed at all times:

- Do not rely on your firearm's safety. Always treat your firearm as if it were loaded and ready to fire. The firearm is safe only as long as you use it safely.
- Never handle a firearm without inspecting the magazine well and the chamber to see if it is loaded.
- Always unload the firearm when finished shooting.
- While unloading, always keep the firearm pointed in a safe direction, remove the magazine, empty the chamber, and visually inspect to ensure no round is present.
- Never cross a fence, climb a tree, cross a ditch, walk, or run with a loaded firearm. Firearms have been known to accidentally fire when dropped, snagged, and struck.
- Always be sure the barrel is clear of obstruction and only carry and load your firearm with ammunition specifically intended for your firearm.
- Never shoot a firearm that may have sustained damage. If damaged, have it examined by a competent gun-smith before shooting.
- Never load or carry a loaded firearm until you are ready to use it. Before loading, ensure you have a stable shooting position and that your muzzle is pointed in a safe direction.
- Never point the muzzle of your firearm at anything that you are not willing to kill or destroy.
- Never place your finger on the trigger, or inside the trigger guard, until you are ready to fire.
- Always wear eye and ear protection when shooting. Operators and bystanders must do so to prevent possible permanent vision and/or hearing loss.
- Never shoot unless you are absolutely sure of your target and what is beyond it. Rifle and handgun cartridges are very powerful, can have a lethal range of several miles, and can often penetrate walls and metal.
- Never fire at hard objects or water as this may cause projectiles to ricochet and result in death, serious injury, or property damage.
- Never handle or shoot this firearm if you have consumed alcohol, or if you are taking drugs or medication that could impair your vision, physical responses, or judgement.
- Use only high quality, commercially manufactured ammunition in good condition. Only use ammunition of the caliber in which your firearm is chambered (confirm caliber type on firearm). You should always use ammunition that complies with performance standards established by The Sporting Arms and Ammunition Manufacturer's Institute.
- Do not alter this firearm in any way. This firearm was designed to function properly in its original condition. Alterations can make the firearm unsafe.
- Keep your firearm and ammunition separately and in locked storage away from children and unauthorized persons.

Sa vz. 58 Bolt Action Instruction Manual

1. <u>Part I Description of the design of the Sa vz. 58 Bolt Action</u>	4
1.1 General	4
1.1.1. Purpose and properties of the Sa vz. 58 Bolt Action	4
1.1.2. Characteristics of the Sa vz. 58 Bolt Action.....	5
1.1.3. Marking and Numbering of the rifle	5
1.2 Description of the main parts of the rifle	5
1.2.1. Barrel.....	6
1.2.2. The receiver assembly	8
1.2.3. Bolt assembly	11
1.2.4. The trigger mechanism.....	14
1.2.5. Stock assembly, grip and handguards	16
1.3 Accessories and their description	18
1.3.1. Accessories.....	18
1.3.2. Accessories descriptions	18
1.4 Ammunition	20
1.4.1. Types of cartridges	20
1.4.2. Loading the magazines	20
2. <u>Functioning of the rifle and troubleshooting, storage, inspections, maintenance and repairs</u>	21
2.1 Functioning of the parts and mechanisms of the rifle	21
2.1.1. Preparing the rifle for shooting.....	21
2.1.2. Functioning of the rifle parts.....	21
2.2 Troubleshooting	23
2.2.1. General rules for preventing malfunctions	23
2.2.2. Typical malfunctions, their causes and solutions.....	24
2.3 Storage	25
2.3.1. Storing the rifle	25
2.4 Inspection of the rifle	25
2.4.1. Principles of inspection of the rifle	25
2.4.2. Disassembling the rifle.....	29
2.4.3. Assembling the rifle	30
2.5 Maintenance	31
2.5.1. The main principles of rifle maintenance.....	31
2.5.2. Cleaning and preserving agents	32
2.6 Repairs	33
2.6.1. Repairing the Rifle	33
3. <u>Technical parameters</u>	34
4. <u>List of components</u>	37

1. Description of the design of the Sa vz. 58 Bolt Action

1.1. General

1.1.1. Purpose and Properties of the Sa vz. 58 Bolt Action

The Sa vz. 58 Bolt Action (hereinafter also referred to as the 'rifle') is a repeating rifle. The firing is effective up to 500 meters at individual ground targets and 800 meters at group targets. The sight is adjustable from 100 meters to 800 meters in 100-meter increments. Additionally, the rear-sight leaf is provided with a 'U' ('universal') mark for firing at moving targets. The Rifle is designed for sports shooting as well as hunting.



Fig. 1a **The Sa vz. 58 Bolt Action RIFLE**
cal. 5.56x45 mm /general view from the left/



Fig. 1b **The Sa vz. 58 Bolt Action CARBINE**



Fig. 1c **The Sa vz. 58 Bolt Action COMPACT**
cal. 7.62x39 mm /general view from the left/



Fig. 1d **The Sa vz. 58 Bolt Action TACTICAL**

The bolt is locked with a locking piece and unlocked by manual cocking of the bolt carrier. The barrel is pressed in to the receiver. The locking piece, bolt and piston are hard chrome-plated. Each Rifle is supplied with accessories.

1.1.2. Characteristics of the Sa vz. 58 Bolt Action

The Sa vz. 58 Bolt Action is a repeating rifle with a locked bolt in which the bolt is locked by means of a locking piece and opened repeatedly loaded by means of manual cocking of the bolt carrier.

The rifle is of simple construction and easy to handle. When correctly maintained and used, its firing function is reliable and safe even under severe conditions, i.e. in dust, rain or at low and high temperatures.

The trigger mechanism enables it to only fire single shots only. The rear sight is of a folding leaf type. During firing, the cartridges are continuously fed fire single shot only a double stack plastic magazine of an arch-like shape, which holds 30 cartridges. When disassembling the rifle for cleaning and storage purposes, no tools are necessary.

The weight and dimensions of the rifle allow it to be used very comfortably not only at shooting ranges, but also when hunting in woods, mountains, and all other kinds of terrain.

1.1.3. Marking and Numbering of the rifle

Each rifle is marked with the serial number, name of the rifle, caliber, country of origin, name of the manufacturer and the importer.

1.2. Description of the main parts of the rifle

The Sa vz. 58 Bolt Action has the following main parts

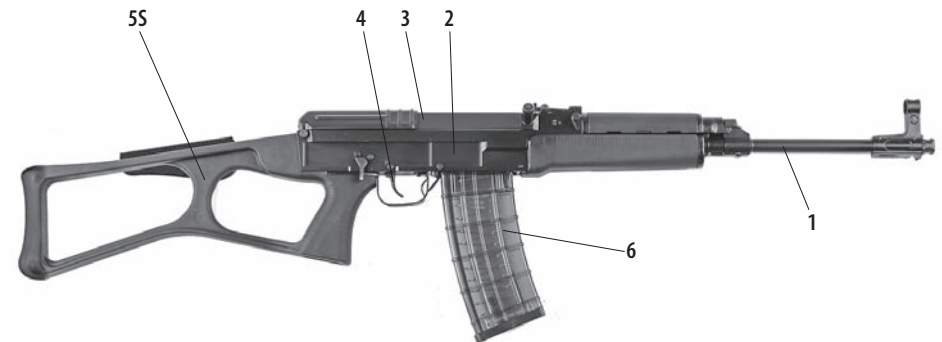

Fig. 2 **Main parts**

1 - barrel, 2 - receiver, 3 - bolt, 4 - trigger mechanism, 5S - stock, 6 - magazine

1.2.1. Barrel

The **Barrel 1** (Fig. 3) is intended to direct the projectile's flight. The barrel has a right-handed bore with four grooves, which produces the four **fields of the rifling**. The barrel is pressed in to the receiver and locked with a pin.

The barrel is pressed in to the receiver and locked with a pin.

In the rear part of the bore, the twist passes into a smooth **cartridge chamber** whose shape and dimensions correspond to the cartridge caliber. The cartridge chamber passes into the rifling (the rifled part of the bore) via the transition cone which enables the projectile to gradually cut into the grooves.

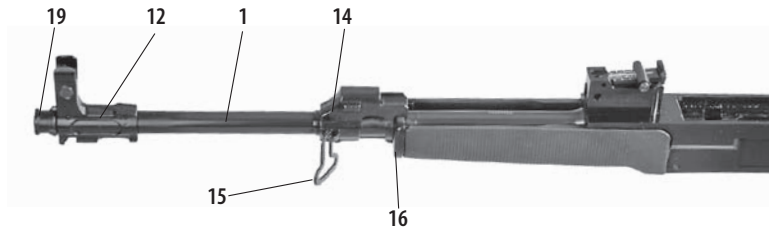

Fig. 3 **Barrel assembly** /general view/

1 - barrel, 12 - front sight base, 13 - muzzle nut, 14 - gas adapter, 15- front swivel, 16- lower handguard hoop

The external cylindrical surface of the barrel is stepped four times. Near the muzzle, on the barrel, is pressed front sight base 12, which is locked by two pins 121 in order to prevent turning (Fig. 4). In front of the front sight base is muzzle nut 13 screwed on to the threaded muzzle.

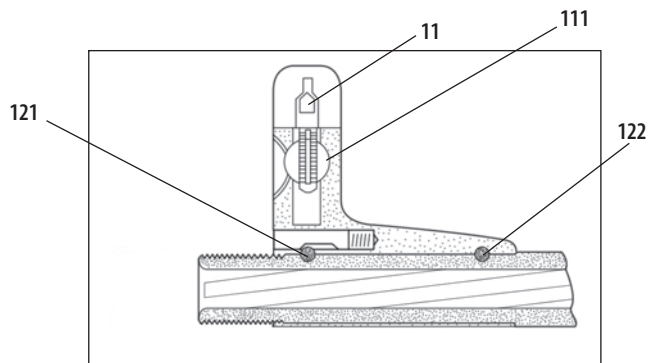

Fig. 4 **Front sight base** /sectional view/

11 - front sight, 111 - front sight pin, 121 - front sight base pin

Muzzle has an M14 x 1 twist and is protected by a **muzzle nut 13** (Fig. 5).



Fig 5. **Muzzle nut** /side view/



Fig. 6 **Gas adapter**

There are no openings in the gas adapter for the gases to escape from the barrel and operate the piston.

Front sight 11 (Fig. 4) together with rear sight 21 form the sights of the rifle and are used for aiming of the rifle. The front sight is of a cylindrical shape, provided with a thread in its bottom part, longitudinally cut and opened. It is screwed into the front sight pin 111 and the front sight thread part enables it to be adjusted for height. After screwing the front sight into the front-sight pin, the opened part springs, thus preventing the front sight from turning spontaneously.

Front sight nut 111 is placed crosswise in the upper part of the front sight holder and is intended for screwing in the front sight and for its side adjustment when zeroing in. The front sight holder is shaped in its upper part in order to form a column and ends with front-sight cover wings ensuring that the front sight is protected against damage.



Fig. 7 **Frame**

There is no openings for the piston in the frontsection of the receiver as the Bolt Action model does not contain any piston.

1.2.2. The receiver assembly

The receiver (Fig. 8) is one of the main parts of the rifle; it joins the other rifle parts together as a whole and guides the bolt. It consists of the receiver proper 2, rear sight assembly 21, ejector 22, bolt catch 23, magazine catch 24, receiver cover pin 25 and receiver cover pin safety pin 26.

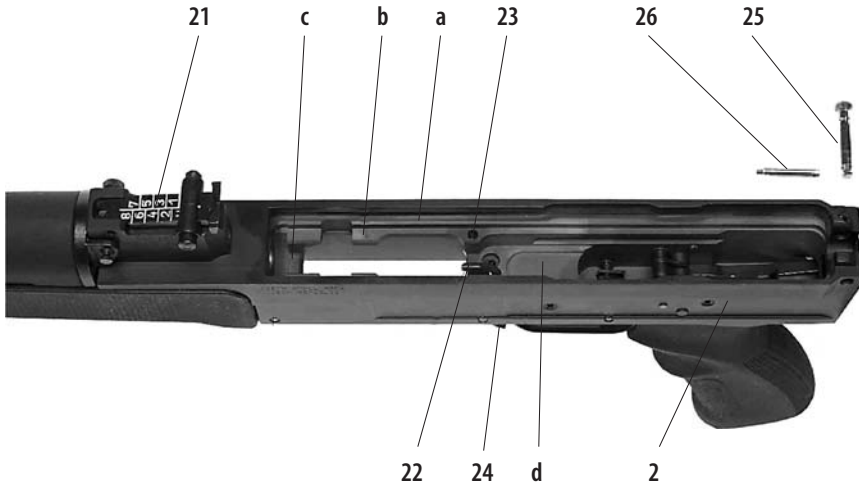

Fig. 8 **The receiver assembly** /top view/

2 – receiver, 21 – rear sight, 22 – ejector, 23 – bolt catch, 24 – bolt catch, 25 – receiver cover pin, 26 – receiver cover pin safety pin, a – guiding grooves, b – locking lugs, c – feed ramp, d – bridge

On both sides in the rectangular recess of the receiver are guiding grooves a, b along which the bolt carrier and the bolt move. In the front thickened part of the bars b are recesses in which the locking lugs of the locking piece snap when locking the breech. The front wall between the guide bars is chamfered, thus forming the **ramp c** which enables the cartridge to be easily pushed into the cartridge chamber. The barrel is inserted into the front part of the receiver. In the middle of the receiver is **bridge c** which divides the entire inner space of the receiver into two parts: the front magazine well and the rear recess for seating the trigger mechanism. In the front magazine wall is a lug which engages in the corresponding recess in the upper part of the front edge of the receiver magazine well.

Rear sight (Fig. 10) enables the needed angles of the tangent elevation to be set; the rear sight is fixed in the rear sight base. Rear sight 21 (Fig. 10) consists of rear sight slide 211, rear sight plunger 212 with spring 213 and rear sight feather 214.

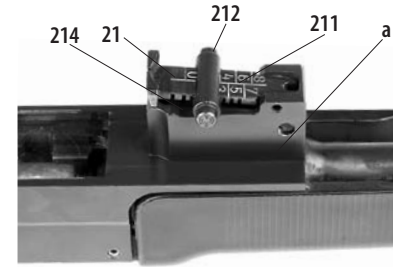

Fig. 9 **Rear sight assembly**

21 - rear sight, 211 - slide, 212 - rear sight plunger, 214 - rear sight feather, a - rear sight base

The rear sight base forms one piece with the receiver. The sides of the front elevated part are provided with openings for the rear sight pins. The side walls of the rear sight base form ramps. Between the side walls is a recess for shifting in the rear sight feather. In the rear part of the recess is a dimple for fixing the rear sight feather.

Rear sight 21 is intended for setting the slide in order to correspond to an appropriate range; it is of a plate-like shape. There are pins, on its front narrowed part, by which the leaf is swingingly mounted in the openings of the rear sight base. The rear sight leaf is inserted into the base by means of the rear sight feather. At the rear end of the leaf is the rectangular V notch (b). On the top end of the leaf are gauge lines with figures from

1 to 8 (the odd figures are on the right and the even figures on the left) which indicate the range of fire in hundreds of meters. The rear sight can consequently be set at a distance from 100 meters to 800 meters. Additionally, the left-hand side of the rear sight leaf is provided with a gauge line marked U, 'universal', which indicates a range of fire up to 300 meters. The dimple in the front narrowed part of the rear sight leaf is designed for the pointed end of the front sight spanner which is used for disassembling the rear sight.

Slide 211 of the rear sight is slipped over the rear sight leaf. In the middle part of the slide is a rectangular window through which the slide can be slipped over the rear sight leaf. The inside cylindrical cavity in the slide is intended for bearing plunger 212 with spring 213. The rear sight is held in the desired position by the rear sight feather 214.

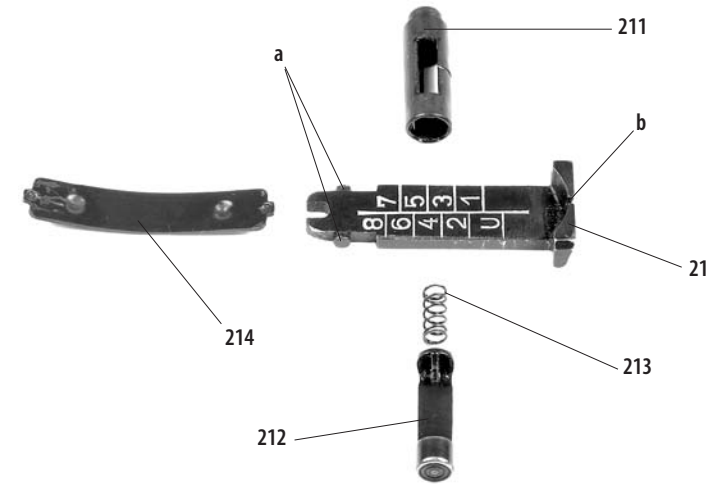

Fig. 10 **Rear sight** /exploded view/

21 - rear sight, 211 - slide, 212 - rear sight plunger, 213 - rear sight plunger spring, 214 - rear sight feather, a - sight pins, b - sight notch

Rear sight plunger 212 locks the slide in the set position by snapping the chamfered lug of the plunger in the appropriate notch on the right-hand edge of the rear sight leaf. The plunger lug is held in the notch on the rear sight leaf by the pressure of the plunger spring. The spring is seated in the cavity of the slide

Rear sight feather 214 with its front end presses the bottom side of the rear sight in front of the leaf pins so that the slide is constantly forced down to the rear sight ramps. The rear sight feather is shifted with its rear end into the groove in the rear sight base thereby preventing vertical motion of rear end of the feather.

Ejector 22 (Fig. 8) is placed in the grooves in the upper part of the bridge. The ejector is locked against shifting out by means of the dimple. The face surface of the ejector is chamfered so as to ensure that the contact of the ejector with the base of the cartridge case is almost one-point and on the left of the vertical axis of the firing pin when the cartridge is ejected. This guarantees that the direction of the ejection of the cartridge case ejected from the rifle is correct, i.e. upwards and to the right.

On the right-hand side from the ejector is situated bolt catch 23 (Fig. 11 and 12). After firing the last cartridge from the magazine, the bolt catch retains the bolt in the rear (open) position. The bottom part of the bolt catch is divided by a recess into two branches; the shorter one is controlled by the magazine follower lug and the longer one (with the cross knurling) is intended for manual shifting out of the bolt catch, thus holding the bolt in the opened position if this is necessary for inspection, cleaning, repairs or other reasons. When the bolt is moving forward, it makes contact with the cylindrical part of the bolt catch. Once the pressure from the bolt catch is removed (when the magazine is taken out of the receiver magazine properly) and the bolt moved slightly backwards, bolt catch spring 231 pushes the bolt catch back into the receiver thus disengaging it from the bolt.

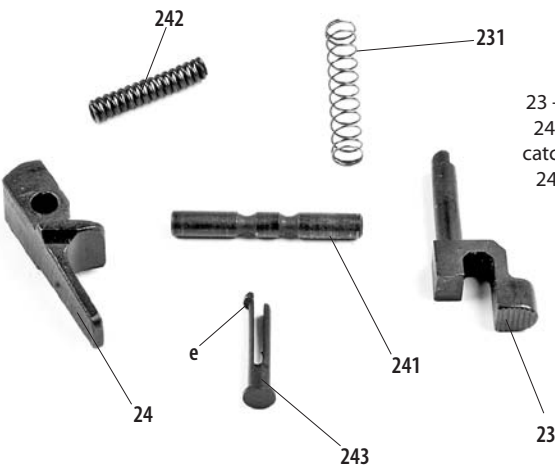

Fig. 11 Receiver components
23 - bolt catch, 231 - bolt catch spring,
24 - magazine catch, 241 - magazine
catch pin, 242 - magazine catch spring,
243 - magazine catch pin safety pin,
e - lug

From below on the left-hand side of the ejector, on pin 241 is the swingingly seated magazine catch 24 which keeps the magazine inserted in the receiver, thus preventing it from falling out. The magazine catch is provided with a lug which, through actuation of spring 242, snaps in behind the lug on the rear edge near the magazine feed lips. With its one end the spring is seated in the pocket of the receiver bridge while the other end bears on the cylindrical recess of the magazine catch.

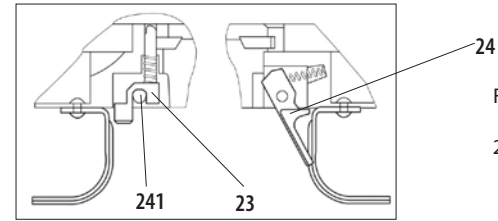

Fig. 12 Bolt catch and magazine catch /
sectional view/
23 - bolt catch, 241 - magazine catch pin,
24 - magazine catch

Magazine catch pin 241 is common for both the magazine catch and the bolt catch. It is locked against loosening by safety pin 243 which is longitudinally cut up and opened. At the longer end of the cut-up part is external luge which snaps in behind the edge of the recess in the upper wall of the receiver bridge. The safety pin with its cylindrical part fits into the circumferential groove on pin 241.

In the bottom of the receiver are two rectangular openings. The trigger passes in to the first one while the other is designed for seating the shaped nut of the grip screw. **Trigger guard 28** is riveted to the bottom of the receiver. The rear wall of the receiver is provided with a thread for fixing the stock to the receiver's rear face and additionally with a groove for fixing the return mechanism. The position of the stepped return mechanism is locked by receiver cover pin 25 (Fig. 8) which is kept in position by the force of receiver cover safety pin 26 which presses against the two circumferential grooves of the receiver cover pin. Receiver cover safety pin 26 is mounted vertically in the wall of the receiver rear right-hand corner and is pushed by the rear arm of the trigger mechanism feather.

1.2.3. Bolt assembly

The bolt makes possible the action of the rifle; pushing the cartridges from the magazine and inserting them into the cartridge chamber; locking the cartridge chamber at the moment of firing, igniting the cartridge primer, pulling out and ejecting the fired cartridge case.

The bolt assembly has the following parts: the bolt carrier, bolt, locking piece, and striker.

Bolt carrier 35 (Fig. 13) actuates the bolt, the locking piece and the disconnecter. The front wall of the bolt carrier is provided with a recess against which the bottom part of the piston strikes at the moment of firing. On the right-hand side of the bolt carrier is cocking lever a which is designed for hand-operated cocking of the bolt. Both sides of the bolt carrier are provided with guide grooves b which are interrupted at about the half way point by a recess whose shape corresponds to the corresponding lugs in the receiver. This recess is intended for inserting the bolt carrier in the receiver and for taking it out again. The rear wall of the bolt carrier is provided with three longitudinal openings. The top opening is made in order to house the return spring while the other two openings are designed to lower the weight of the bolt carrier.

The bottom part of the bolt carrier has a recess which is divided into two parts by partition wall c. The partition wall together with unlocking tip d control the motion of the locking piece. The unlocking tip formed in the front part pulls the locking piece from the locked position. The unlocking-tip bottom surface forms a guide for the bolt. Bolt carrier shaft e provided with an opening for the striker is situated in the bottom rear part of the bolt carrier. When disassembling and assembling the bolt, the striker is locked against falling-out by a lug which projects from the left-hand side into the opening for the striker. The left hand side of bolt carrier shaft bridge f actuates the disconnecter.

Locking piece 36 (Fig. 13) ensures the proper locking of the cartridge chamber. It is of horse-shoe shape; both arms of the locking piece pass at the ends into joints m by which the locking piece is wingingly carried in the bolt bearings. In the front bottom part of the locking piece are situated locking lugs n which, when the locking piece is in a locked position, transmit the pressure produced at the moment of firing to the receiver.

Striker 37 (Fig. 13) strikes against the firing pin. It is of a hollow cylinder shape closed at its front end by a smooth front wall coming into contact with the firing pin. The rear open end has a head provided with grooves by which the striker is guided along the bars in the receiver. The striker head is elongated downwards, thus forming a nose o. The cylindrical part of the striker is relieved along the periphery by means of six longitudinal grooves. The groove on the left-hand side of the striker is closed on its front side and is elongated backwards as far as the striker head. Along the groove is guided the projection of the bolt carrier. The projection prevents the striker from falling out of the bolt carrier. This closed groove is joined with the neighboring longitudinal groove by means of a cross groove which enables the projection of the bolt carrier to pass to the closed groove. Striker spring 382 (Fig. 17) is inserted with its one end into the cylindrical cavity of the striker.

Bolt 3 (Fig. 14) is provided in its front wall with a bed with a centric opening for the cartridge base. Moving free in this opening is firing pin 31 (Fig. 14). Extractor 32 with its claw reaches the edge of the cartridge case bed. The bottom edge of the cartridge base bed is bound by ramming lugs i (Fig. 13) which push the cartridges out from the magazine into the cartridge chamber. The ejector passes through the groove between these ramming lugs when the bolt is moving backwards. The recess on the right-hand face wall forms a stop for the bolt catch. The bolt is guided in the carrier by grooves j which are interrupted on both sides of the bolt by the recess intended for the locking piece (Fig. 13). The bolt is provided with an opening for the striker at the back.

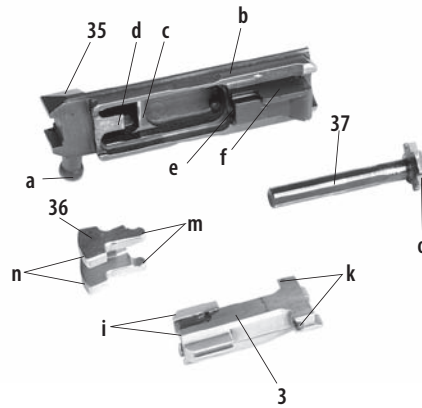

Fig. 13 Bolt assembly
 3 – bolt; 35 – bolt carrier, 36 – locking piece; 37 – striker; a – cocking lever; b – guide grooves; c – partition wall; d – unlocking tip; e – bolt carrier shaft; f – left-hand side of bolt carrier shaft bridge; i – ramming lugs; k – bearings; m – joints; n – locking lugs; o – striker nose

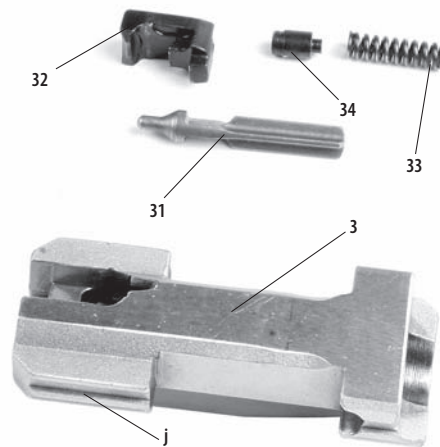

Fig. 14 Bolt /disassembled/
 3 – bolt, 31 – firing pin, 32 – extractor, 33 – extractor spring, 34 – extractor stay, j – grooves

Firing pin 31 (Fig. 14) ignites the cartridge primer. It is mounted in the body of the bolt. The firing pin is prevented from falling out by the extractor bottom part which reaches the groove in the firing pin and thus also limits the return motion of the firing pin. The firing pin forward motion is limited by the conical surface of the firing pin which bears against the corresponding surface in the bolt body. The thickened rear end of the firing pin projects into the cavity designed for the striker and is relieved by three external longitudinal grooves.

Extractor 32 (Fig. 14) extracts the fired cartridge case from the cartridge chamber by means of a claw which, pressed by **extractor spring 33**, snaps into the groove of the base of the cartridge case. The extractor spring is seated in the cavity of the bolt and presses against **stay 34** which in turn actuates the extractor.

The return mechanism (Fig. 15) makes the bolt return to the extreme front position. It consists of return mechanism base 38 with receiver cover 381, striker spring 382, striker spring guide 383, return spring 384, return spring guide 385 and return spring locking block 386.

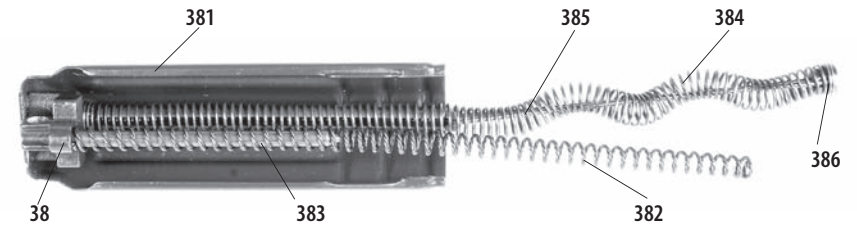

Fig. 15 The return mechanism
 38 – return mechanism base; 381 – receiver cover; 382 – striker spring, 383 – striker spring guide, 384 – return spring, 385 – return spring guide; 386 – return spring locking block

Return mechanism base 38 unites all the parts of the return mechanism in order to form one unit. The base is riveted with receiver cover 381. The base is formed by a plate to which return spring guide 385 and striker spring guide 383 are fixed. In the rear wall of the base is a projection by means of which the return mechanism base is positioned in the recess in the rear part of the receiver. In order to prevent the receiver from falling out, the base is locked by receiver cover pin 26 (Fig. 8).

Receiver cover 381 is a stamp riveted with the base. It covers the rear part of the rifle's receiver.

Striker spring 382 throws the striker against the firing pin. It is placed on striker spring guide 383 which is pivoted on the return mechanism base and allows a mild double-sided wobbling.

Striker spring guide 383 is a steel rod which supports striker spring 382. The striker spring guide is provided near the base with a groove in which the turn of the striker spring sits. Both end turns of the striker spring have their diameters reduced so that the striker spring, regardless of which of its ends has slipped over the guide, cannot be shifted out spontaneously.

Return spring 384 makes the bolt return to the front position. It is placed over return spring guide 385. The guide is made of steel wire and its bent ends engage the notch on the return spring locking block 386.

Return spring guide 385 consists of a stick and a wire. The stick is fixed in the return mechanism plate by means of a cross pin which allows a mild double-sided wobbling of the stick.

1.2.4. The trigger mechanism

The trigger mechanism makes firing possible and is provided with a device locking the rifle against spontaneous fire. It is situated in the rear recess of the receiver on two pins.

The trigger mechanism (Figs. 16 and 17) has the following parts: trigger 4, trigger pin 41, disconnecter 42, disconnecter spring 43, disconnecter pin 44, sear 45, sear pin 46, trigger mechanism feather 47, safety catch 48 and safety catch holder 49.

Trigger 4 is pivoted in the receiver on pin 41 and controls the release of the striker through the sear. The rear part of the trigger fingerpiece projects to form projection a which when leant against the receiver, restricts backward motion of the trigger. In the top part of the trigger is a cut-out in which disconnecter 42 is seated on disconnecter pin 44 (Fig. 18). In the rear part of the trigger is an oblique bed for **disconnecter spring 43**.

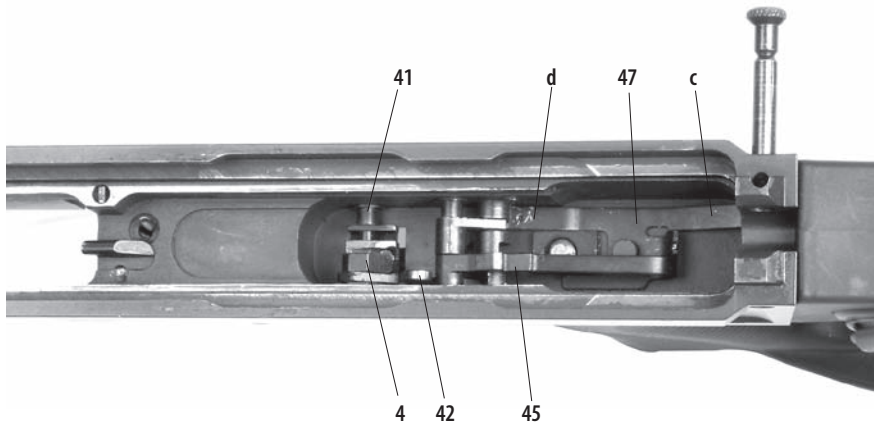

Fig. 16 **Trigger mechanism** /in receiver/

4 - trigger, 41 - trigger pin, 42 - disconnecter, 43 - disconnecter spring, 45 - sear, 46 - sear pin, 47 - trigger mechanism feather, c, d - trigger mechanism feather arms.

By means of the lug, **disconnecter 42** lowers **sear 45**, by pulling its projection b (when the trigger is squeezed, if the safety catch is set in the "fire" position). The lug projects on the right-hand side of the free end of the disconnecter. The disconnecter is pivoted on pin 44 in the cut-out of the trigger. On the top of the disconnecter is a projection which is controlled by the left-hand side of the bolt carrier shaft bridge during its backward motion. In the bottom part it is provided with a recess against which disconnecter spring 43 leans with its one end. The other end of the disconnecter spring is seated in the trigger bed. The disconnecter spring pushes the disconnecter so as to make it come into contact with the safety catch.

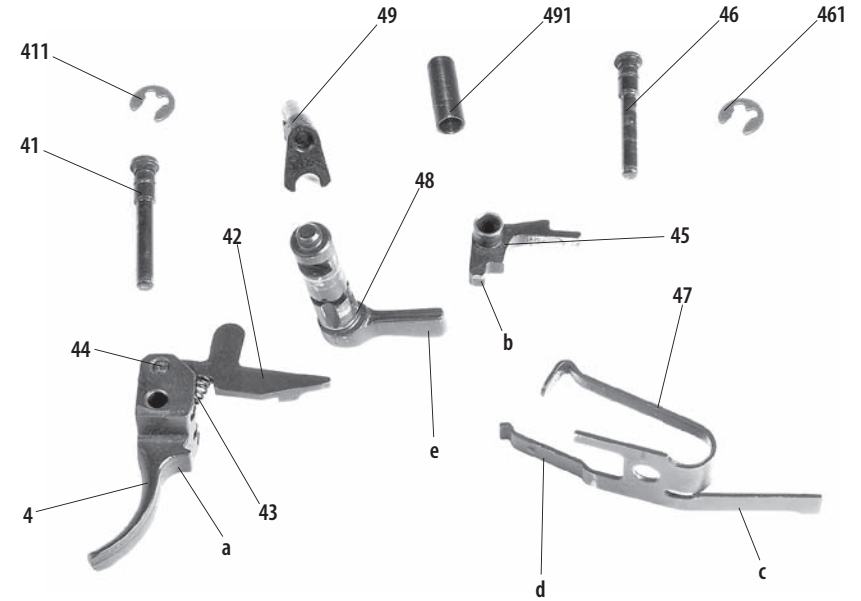

Fig. 17 **The trigger mechanism** /disassembled/

4 - trigger, 41 - trigger pin, 411 - trigger pin e-clip, 42 - disconnecter, 43 - disconnecter spring, 44 - disconnecter pin, 45 - sear, 46 - sear pin, 461 - sear pin e-clip, 47 - trigger mechanism feather, 48 - safety catch, 49 - safety catch holder, 491 - safety catch holder spacer, a - trigger projection, b - sear projection, c, d - trigger mechanism feather arms, e - safety catch wing

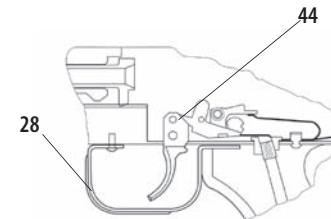

Fig. 18 **The trigger mechanism** /sectional view/

28 - trigger guard, 44 - disconnecter pin, 47 - trigger mechanism feather

The sear is pushed into engagement with the nose of the striker by the **trigger mechanism feather 47** arm (Fig. 18). The feather is mounted on the bottom of the recess of the receiver. It is locked by the rivet of the trigger guard rear end on which the trigger mechanism feather is placed with its circular opening in order to prevent longitudinal displacement. It is side guided by the screw nut of the grip. Arm c of the feather presses receiver cover pin safety pin 26 while the bent end of arm d snaps in the recess of the safety catch, thus locking its position. The dimple on arm d is intended for supporting the pointed end of the front sight spanner when taking out or inserting the safety catch.

Safety catch 48 enables firing and prevents unintended firing. It is a cylinder provided with wing e at one of its ends. The cylindrical part of the safety catch is provided on its left hand side with a cutting placed opposite the disconnecter. Thus, when the wing of the safety catch is in the "Fire" position, i.e. pointing forward, the disconnecter slides into the cutting, raises up and engages the sear. **When the wing is in the vertical position – locked** – the cutting is 90 degree to the disconnecter, which is thus pushed down by the cylindrical part of the safety catch and out of reach of the sear.

Safety catch holder 49, which is placed on the sear pin, prevents the safety catch from falling out. The wing is provided with longitudinal grooves in which the bent end of the trigger mechanism feather arm snaps, when the safety catch changes its adjustment

1.2.5. Stock assembly, grip and handguards

The Sa vz. 58 Bolt Action has a stock assembly (Fig. 19) whose main parts are stock (either fixed polymer 5P, or metal folding 5F, or telescopic 5T), grip 53, upper handguard 55 and lower handguard 56. Stock elongates the rifle and enables the rifle to be correctly rested against the shoulder when firing. Various rifle models are delivered with optional stocks and grips upon request (for standard stock modes), see Fig. 19).

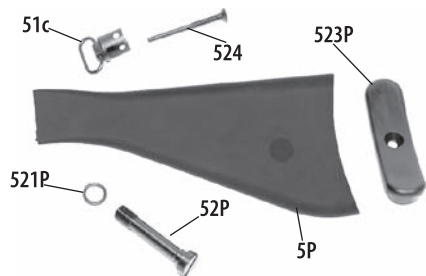
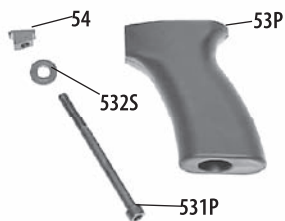

Fig. 19a Polymer fixed stock
 5P - polymer fixed stock, 51c - rear swivel, complete, 52P - polymer fixed stock screw, 521P - polymer fixed stock screw washer, 523P - polymer fixed stock butt plate, 524 - butt plate screw common to rear swivel



Fig. 19b Metal folding stock with grip
 5F - Folding stock, 51F - Suspension of the folding stock, 511F - hinge of the folding stock, 52F - Folding stock scre, 53E - Ergonomic grip, 531E - Ergonomic grip screw



Polymer grip
 53 - polymer grip, 531 - polymer grip screw, 532S - grip screw washer, 54 - grip screw nut

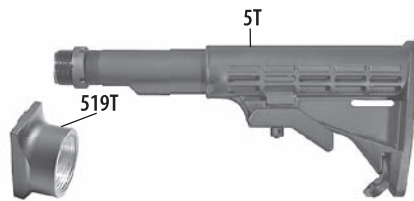

Fig. 19b Telescopic stock
 5T - telescopic stock, 519T - adapter for telescopic stock

The grip section is fixed to the receiver by stock grip screw 531s and by stock grip nut 54 which is seated in the recess receiver bottom. The grip screw head is countersunk in the grip and bears against washer 532S.

The handguards make it possible to hold the rifle they are made of polymer and cover portion of the barrel and protect the rifleman's hand against heat when firing. The front handguards consists of the upper and lower handguard.

The upper handguard assembly (Fig. 20) covers the barrel from the top. It consists of polymer upper handguard 55P, metal jacket 551, upper handguard pin 552, upper handguard pin pawl 553, upper handguard pin pawl spring 554, upper hand guard front hoop 555 and rear hoop 556. Upper handguard picatiny rails allow attaching of red dot rights, flesh lights or any other accessories.

Front hoop 555 is welded to the front part of handguard metal jacket 551 which is projected to form tips a by means of which the barrel guard snaps into the grooves of the gas adapter. Upper handguard holder 557 is situated in the middle of the jacket and is the metal piece by means of which handguard guard 55P is locked against turning. Projection b in the front part of the handguard forms a guide for the piston instead of the cut-off upper part of the gas cylinder. Rear hoop 556 is spot welded to the rear part of the handguard jacket and is provided with two projections c through which upper handguard pin 552 passes. The pocket for pin pawl spring 554 and pin pawl 553 is situated in the right-hand projection, which when pressed by the spring, snaps into the circumferential grooves on the handguard pin. In this fashion the handguard pin is locked against being pushed out from the left-hand projection or against falling out from the right-hand projection when removing the handguard off the weapon. Plastic handguard 55P is shifted with its ends into the grooves in upper handguard bas.

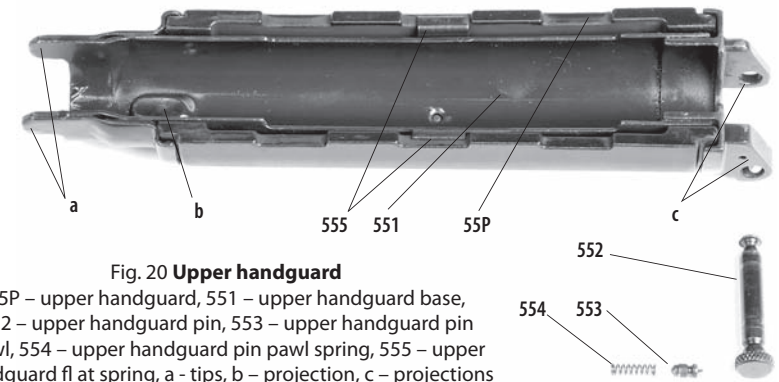

Fig. 20 Upper handguard
 55P - upper handguard, 551 - upper handguard base, 552 - upper handguard pin, 553 - upper handguard pin pawl, 554 - upper handguard pin pawl spring, 555 - upper handguard fl at spring, a - tips, b - projection, c - projections

Lower handguard 56P (Fig. 19) is made of polymer and covers the barrel from below. The front end of the lower handguard is shifted in lower handguard front hoop 16 which is slipped over the barrel and snapped in by the gas adapter lug. The rear end of the lower barrel guard is fixed to the receiver by pin 561 (Fig. 19).

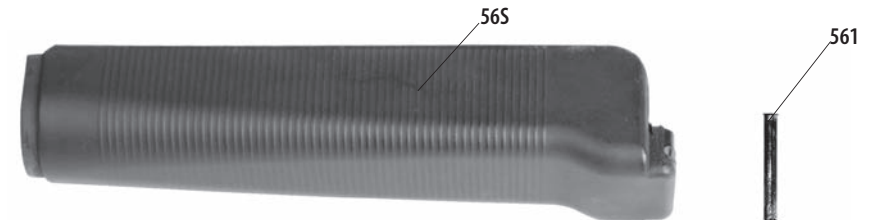

Fig. 21 Lower handguard
 56P - lower handguard, 561 - lower handguard pin

1.3. Accessories and their description

1.3.1. Accessories

Each Rifle is provided with the following accessories:

- | | |
|-------------------------|--------------------|
| two 30 rd magazines (6) | brush (93) |
| sling (8) | copper brush (931) |
| cleaning kit bag (9) | loop (932) |
| cleaning rod I (91) | needle (95) |
| cleaning rod II (92) | |

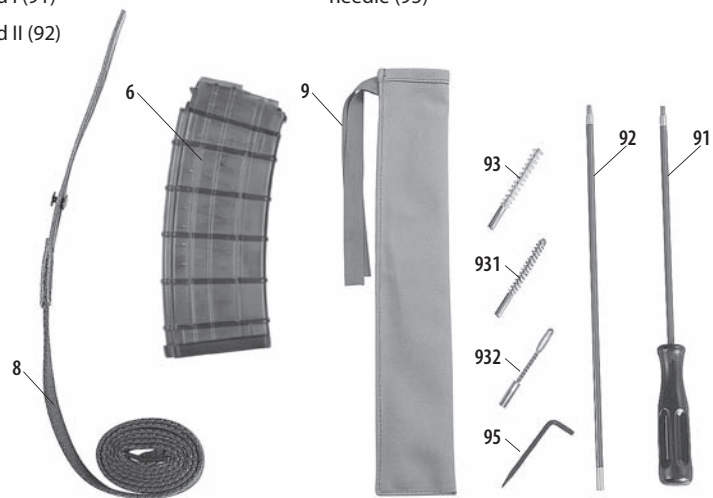

Fig. 22 Accessories

6 – magazine, 8 – sling, 9 – cleaning kit bag, 91 – cleaning rod I, 92 – cleaning rod II, 93 – brush, 931 – copper brush, 932 – loop, 95 – needle

1.3.2. Accessories description

Magazine 6 (Fig. 23) is intended for continuous loading of the rifle with cartridges during firing. It is of an arched shape and takes 30 cartridges. It consists of magazine body 6H, magazine follower 61H with magazine spring 62H, magazine floor plate safety 63H and magazine floor plate 64H.

Magazine body 6H, of the 5.56 x 45 mm cal., is made of semitransparent high impact or of metal and forms a box for the cartridges and the magazine follower with a spring. The case opens at both ends. The sidewalls are provided with rails intended for guiding both the cartridges in the magazine and in the magazine follower. The magazine head is provided with projections (a and b) on the front

and rear edges in order to hold the magazine into the receiver. The magazine's head is provided with a rim (c) which restricts the depth of its insertion into the receiver. The lower edges of the sidewalls of the magazine case are provided with grooves (d) into which magazine floor plate 64H is fitted.

Magazine follower 61H pushes the cartridges into the magazine feed lips through the action of magazine spring 62H. The rear wall of the magazine follower is provided on its right hand side with a projection for lifting up the bolt catch after having fired the last cartridge from the magazine.

Magazine spring 62H pushes the follower into the magazine feed lips. It is made of steel wire which is yellow chromate treated. With its one end it is shifted in and leans against the magazine follower 61H bottom where it is seated on a rail. The other end of the magazine follower spring leans against the magazine's safety catch on the magazine floor and is again seated on the magazine safety rail.

Magazine floor plate safety 63H locks the magazine floor plate against spontaneous shifting out. The middle part is provided with a projection which snaps into the opening of the magazine floor plate. The rail in the middle of the safety catch is intended for positioning the magazine spring.

Magazine floor plate 64H closes the magazine from below. It has a round opening in the middle for the projection of the magazine bottom safety catch.

Sling 8 makes it possible to carry the rifle; it is 1,220 mm long and 26 mm wide. A small buckle is sewed on to one end of the sling by which the sling may be shortened or extended. At the other end, the sling is provided with a sewed on leather fastening strap with an opening for the connecting button. When fixing the sling to the rifle, this must be first pulled through the rear swivel of the leather fastening strap, then through the small buckle and then the leather fastening strap should be pulled through the front swivel on the rifle and the connecting button should be buttoned up.

Cleaning kit bag 9 is made of strong textile material and is designed to hold all the cleaning accessories as well as needle 95.

Cleaning rod I 91 is intended for cleaning and lubricating the bore and the cartridge chamber. One end of the upper part of cleaning rod I is provided with a thread to which cleaning rod II or any of the three extensions found in the cleaning kit can be attached. Lower end of cleaning rod I is fitted with plastic handle for better grip and the whole rod is covered with soft plastic sheath to prevent possible damage to the bore or muzzle.

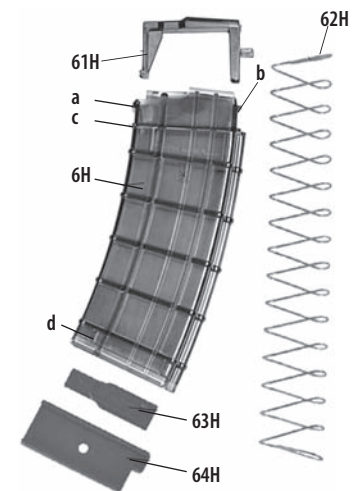

Fig. 23 Magazine, cal. 5.56 x 45 mm

/disassembled/; metal magazines for the 7.62 x 39 cal. consist of the same parts; 6H – magazine body; 61H – magazine follower; 62H – magazine spring; 63H – magazine floor plate safety; 64H – magazine floor plate; a, b – projections, c – rim, d – grooves

Cleaning rod II 92 works as an extension of cleaning rod II.

Brush 93 is used for cleaning and oiling the bore, the cartridge chamber and the gas cylinder.

Copper brush 931 is used to clean very dirty bores, which are hard to clean with regular brush.

Loop 932 allows the use of cloth to wipe dry, oil and conserve the bore.

Needle 95 is the only tool used when disassembling the rifle.

1.4. Ammunition

1.4.1. Types of cartridges

Only 5.56 x 45 mm (.223 Rem) cartridges may be used in the Sa vz. 58 Bolt Action, cal.5.56 x 45mm (.223). In the rifles cal. 7.62 x 39 mm only approved ammunition cal. 7.62 x 39 mm may be used. They should only be of excellent quality and manufactured by a company known for their quality control. The rifle functions reliably with all ammunition types from all main ammunition producers, as well as with all bullet types (FMJ, SP, HP). Nevertheless, among individual ammunition manufacturers there are rather big differences between technical parameters of individual ammunition types (particularly powder quantity, extraction forces, etc.). Thus, different ammunition types from different manufacturers behave in a different way in the same rifle. So, in relation to the ammunition type used, the user may observe big differences not only in the fire precision, but also in case ejection distance. The case ejection distance from a rifle should not be shorter than 1 m and longer than 4 m.

Cartridges should be of a good quality. Cartridges with rusty have been unpacked for a longer time must be wiped with a dry cloth before loading the magazine, and checked for length and turning of the bullets. When some cartridges are in use and frequently rammed into magazines for a longer time, loosening of the bullet in the cartridge case neck, possible pushing in of the bullet into the cartridge case or turning of the bullet may occur. In these cases, the water-tightness and oil-tightness of the cartridges are decreased. Cartridges with pushed-in or turning bullets must not be used, but disposed according to valid regulations. **Never use defective cartridges for firing** (those considerably rusted, with damaged cartridge cases or bullets, with a damp or oiled powder charge or with bullets pushed in the cartridge cases and the like).

Never strike the cartridge, primer or bullet with a hammer or other hard objects.

1.4.2. Loading the magazine

The magazine can be loaded by hand (Fig. 23). Before loading, the magazine must be wiped dry. When loading, the magazine taken out of the rifle should be held in the left hand so that the magazine follower is up and the front wall of the magazine faces the loader's body. The cartridges should be placed by the right hand in to the magazine follower and pushed underneath the magazine feed lips and further right to the rear wall of the magazine. Each of the next rounds is placed on to the previous rounds, but pushed into the magazine body in the same manner as the first round.



Fig. 23 – Loading the magazine

2. Functioning of the rifle and troubleshooting, storage, inspections, maintenance and repairs

2.1. Functioning of the parts and mechanisms of the rifle

2.1.1. Preparing the rifle for shooting

Directly prior to firing, wipe dry the bore and the cartridge chamber.

When disassembling, cleaning and assembling the rifle, all the components should be inspected and checked to see whether they are worn to an excessive degree, battered, broken or damaged in some other way. When assembling, the functioning of the particular mechanisms should be checked. Special attention should be paid to checking the functioning of the assembled trigger mechanism, the reliable functioning of the safety catch, to the disconnecter, to the sear and the condition of the magazine.

After completely assembling the rifle, the functioning of the bolt should be checked by hand cocking. Proper feeding is checked by charging the rifle with a few practice rounds from the magazine (by hand cocking).

The rifle is made ready for firing by inserting the loaded magazine into the magazine well of the receiver and cocking the gun by moving the bolt into the extreme rear position from which it is released without holding the bolt handle any longer or by moving the bolt forward by hand. During this operation the finger must be off the trigger. The safety catch should be turned into its forward (fire) position only prior to firing.

2.1.2. Functioning of the rifle parts

Firing

One may open fire at an object after setting the rear sight to an appropriate range of fire and after adjusting the safety catch wing into the "fire" position, i.e. forward.

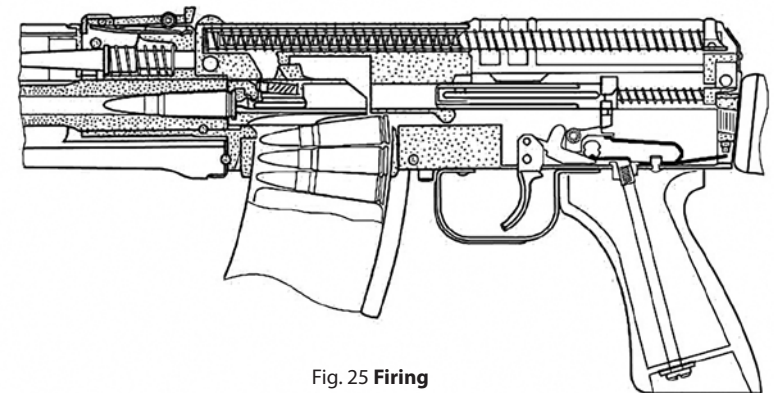

Fig. 25 Firing

When turning the safety catch wing into the position for firing, the safety catch engages the disconnecter, by putting it into the safety catch groove, with the sear. The disconnecter, which is being constantly pushed up by its own spring, hooks the sear and controls its lowering and lifting.

By squeezing the trigger to which the disconnecter is pivoted, the sear is lowered and the striker, which is under the pressure of its spring, is released. The striker thus hits against the firing pin which initiates the cartridge primer in the cartridge chamber.

To repeat fire, the bolt carrier must be manually cocked again. With its unlocking tip, the bolt carrier then pulls the locking piece from the locked position. The locking piece folds into the recess in the bolt carrier over the unlocking tip. From this moment on, all the components of the bolt move together backwards. The beginning of the motion of the bolt coincides with beginning the extracting of the fired cartridge case from the cartridge chamber. The fired cartridge case is pulled by the rim of the base by the extractor claw until the moment when the bottom rim of the cartridge case base strikes the ejector and the cartridge case is thrown out of the rifle's receiver upwards to the right.

Meantime, the left-hand side of the bolt's bridge runs onto the disconnecter's lug and depresses the disconnecter, thus disengaging it from the sear so that the sear is lifted up through the action of the arm of the trigger mechanism feather even if the trigger is squeezed. As soon as the bolt moving backwards has run to its extreme rear position, the bolt carrier strikes against the return mechanism base, stops its motion and the whole bolt assembly then returns to its front position, being actuated by the return spring. The striker being driven by the striker spring catches the sear with its nose.

The ramming lug of the bolt pushes the top round out from the magazine feed lips and rams it into the cartridge chamber. The base of the cartridge case bears against the bolt head pocket, at which the extractor claw snaps into the groove of the base of the cartridge case. During the bolt carrier's forward motion, the locking piece falls into the receiver lugs and locks its position.

The rifle may be locked against an unintended shot by adjusting the wing of the safety catch into the vertical position. When in this position, the safety catch disengages the disconnecter from the sear, preventing it from lowering and thus releasing the striker. In this fashion the rifle is not capable of firing if the rifle's safety is in the locked position.

This mode of locking does not in any way restrict the normal functioning of the other parts of the bolt with the exception of the striker. It is consequently possible to load as well as unload the cartridge from the chamber when the weapon is locked. Additionally, possible self-ignition of the cartridge in cartridge chamber when strongly heated up cannot do any damage to the rifle, as bolt can move freely.

Ceasing fire

Ceasing fire may be temporary or permanent.

Firing is temporarily ceased automatically after every shot, irregardless of whether the trigger is released or squeezed; the next single shot may be fired only by repeated cocking of the rifle.

After firing the last cartridge from the magazine, the bolt remains in the rear position; after replacing the empty magazine with the full one and pulling the bolt carrier backwards by its cocking lever, the bolt catch is released (for the follower pushing the catch up is down in the magazine again) and firing may be resumed.

In case of temporary interruption of fire, the rifle will be locked against an unintended shot by turning the wing of the safety catch downwards, as the cartridge chamber has a cartridge inside it and the striker is in the rear cocked position. Firing may be reopened immediately after adjusting the safety catch wing into "Fire" position.

Termination of firing and unloading the rifle

After terminating fire, the rifle must be locked. When unloading the rifle, take out the magazine and through cocking the bolt, eject the cartridge from the cartridge chamber. Then adjust the safety catch wing in the position "Fire", pull the bolt by its cocking lever backwards and with the trigger being squeezed (releasing the striker), let the bolt go to the front position (to release the striker spring). Then re-lock the rifle. Take the remaining cartridges out of the magazine and slide the empty magazine into the rifle.

TROUBLESHOOTING

2.2.1. General rules for preventing malfunctioning

The rifle is a reliable trouble-free firearm if correctly handled, carefully operated and maintained. Nevertheless, if the rifle is exposed to long-lasting activity, there troubles in firing may occur due to wear or breaks to some of the components, due to dirt in the rifle mechanisms, defective cartridges, careless handling or insufficient maintenance of the rifle. The above-mentioned circumstances spoil the normal functioning of the rifle and can result in malfunctions and troubles when firing.

Most malfunctions and troubles which occur when firing the rifle may be easily solved by simple repeating – pulling the bolt carrier by the cocking lever to its rear position; if a malfunction is not eliminated by repeating or, if eliminated, it re-occurs, it is necessary to unload the rifle and find the reason behind the malfunction.

In order to prevent malfunctions in firing, it is necessary:

- To strictly follow the instructions regarding maintenance, disassembling, assembling, cleaning, inspecting and preparing the rifle and cartridges for firing;
- To protect the components and mechanisms of the rifle from dirt;
- Not to use force when removing malfunctions which might cause damage to the components;
- To carefully inspect the cartridges and magazines before loading the magazines. Do not load magazines with defective or rusty cartridges, wipe the cartridges and remove possible impurities with a dry cloth before loading the magazines;
- To oil the components that work against each other during their functioning before firing; clean and dry the bore and the cartridge chamber;
- To check from time to time the condition of the rifle components and mechanisms at breaks in firing, remove thickened lubricant and impurities off the friction surfaces; re-oil the friction surfaces after cleaning them;
- To carefully protect the rifle from penetration of impurities (dust, sand, earth) into the muzzle when firing, when on the move and when taking firing positions; protect the rifle from impact against the ground and other hard objects.

2.2.2. Typical malfunctions, their causes and solutions

Kinds of malfunctions and troubles, their causes and ways of methods of remedy are indicated in the below table:

Malfunction	Cause	Remedy
1. Misfiring No shot after squeezing the trigger	1. Damaged firing pin, if there is no dimple on cartridge primer left by firing pin impact 2. Fatigued or broken striker spring, if poor trace of firing pin on cartridge primer 3. Defective cartridge	1. Replace firing pin. 2. Replace striker spring. 3. After a lapse of about 10 seconds (danger of delayed ignition of powder charge), by hand recharging, eject the cartridge from the chamber. Inspect the ejected cartridge and if the primer shows adequate dimple caused by strike of firing pin, replace the cartridge.
2. Half-closed bolt Bolt carrier does not bear against the face of the receiver.	1. Dirty bolt 2. Defective (deformed) cartridge 3. Dirty cartridge chamber	1. Disassemble the bolt, clean it and oil it. 2. By hand recharging eject the cartridge from the cartridge chamber 3. Clean the cartridge chamber.
3. Cartridge not fed	1. Dirty interior of magazine 2. Broken magazine walls or broken magazine feed lips 3. Fatigued or broken spring of magazine follower 4. Short recoil of bolt - dirty rifle	1. Disassemble and clean the magazine. 2. Replace the magazine. 3. Replace magazine follower spring. 4. Disassemble and clean the rifle.
4. Cartridge case does not extract	1. Broken extractor spring 2. Broken-off extractor claw	1. Replace extractor spring 2. Replace the extractor
5. Cartridge case does not eject	1. Short motion of bolt backwards – dirty rifle 2. Broken piston	1. Disassemble and clean the rifle 2. Replace the piston
6. Cartridge jumps out of the magazine	Magazine follower spring is too strong or feed lips are broken	Replace the magazine
7. Bolt is not retained by bolt catch after firing last round	1. Defective magazine or its spring	1. Replace the magazine or its spring

Any unauthorized repairs of the rifle, or other modifications of the rifle, may result in the termination of the 5-year warranty provided by the manufacturer.

2.3. Storage

2.3.1. Storing the rifle

The rifle should be deposited in a vertical position with the muzzle up or in a horizontal position either on a rifle rack or on a shelf. It can also be suspended by the sling. The bolt should be in the front position, the striker released and the safety catch wing in the vertical (locked) position. The magazines and the accessories should be put in the magazine pouch.

When transported, the rifle should be placed in a special transport box in order to prevent it from damage. If inadequate packaging is used when transporting the rifle, it is of utmost importance to protect the sight devices against damage by wrapping the front sight and rear sight in rags and filling the empty space in the box with rags in order to prevent the rifle from being battered about.

In any of the mentioned modes of deposition, the rifle must not be loaded!

The deposited rifle must be constantly kept safe and the keys from the locks of the racks, shelves, cabinets or safesholding the rifle must be kept in a secure place.

Do not plug the bore with paper, rags or other objects regardless of the storage conditions, or barrel bulge or additional damage may occur.

After terminating shooting, rifle must be cleaned each time. Special attention should be paid to cleaning of the bore and cartridge chamber. All accessories to the rifle must be kept in good condition, clean and appropriately deposited.

2.4. Inspection of the rifle

2.4.1. Principles of inspection of the rifle

Regular inspections of the assembled and disassembled rifle should be carried out regularly. The extent of disassembling should be determined by the inspecting person. The owner of the rifle should inspect it before leaving for the shooting range and during cleaning.

Along with the inspection of the rifle all specified rifle accessories should be inspected.

Procedure for everyday inspection of the rifle

When not used the assembled rifle should be inspected once a month. On inspection of the rifle, it is necessary to check:

- Whether there is any rusty tint on the metal parts of rifle, whether the metal parts are soiled, battered or scratched and whether the plastic parts of the rifle have split or cracked;
- Whether the front sight or rear sight are damaged, whether the sighting gauge marks are opposite each other,
- Whether the functioning of the slide and the rear sight plunger is correct;
- Whether the magazines are undamaged.

Inspection of the assembled rifle

When inspecting the assembled rifle, it is necessary to check:

a) **The functioning of the bolt:** On cocking the bolt, the motion of the components must be trouble-free, without seizing up, with considerable resistance on the part of the return spring. On releasing the bolt, this must move energetically forwards at which the bolt carrier must run as far as its extreme front position and lean against the face of the receiver. If an empty magazine is shifted into the rifle, the bolt catch must retain the bolt in the open position when the bolt moves forward.

Correctness of feeding, extracting and ejecting may be verified by hand charging at which the magazine, inserted in the rifle, is loaded with practice rounds. In this way, the functioning of the magazine, of the extractor and of the ejector may be verified. At the same time, the functioning of the magazine catch is verified. When inserting the magazine into the rifle, the magazine catch must audibly snap in behind the projection at the rear edge near the magazine feed lips. If not depressing the magazine catch, the magazine must not be released from the receiver. After checking the functioning of the bolt, the striker spring should not remain depressed.

b) **The functioning of the trigger mechanism: The functioning of the trigger mechanism should only be checked when using practice cartridges.**

Insert a practice round into the cartridge chamber by hand charging; the safety catch wing is adjusted to the "Fire" position. In the position of the safety catch wing, the striker must be released by squeezing the trigger and audibly striking the firing pin. If the safety catch wing is adjusted in the "Safe" position, i.e., downwards, the striker must not be released upon squeezing the trigger. When adjusting any of the two positions, the safety catch must be turned to such a degree that an audible click is heard; to change the position of the wing, a certain force must be exerted.

c) **The correctness of the rear sight and the front sight:** It is necessary to check whether the rear sight leaf is lacking side clearance and is not bent. If the plunger is depressed, the slide must easily move along the leaf and must be forced down by the rear sight feather to the rear sight ramp in all positions. The plunger lug must be able to snap into all the notches on the leaf. Regarding the front sight, it is necessary to verify whether it is damaged, whether the sighting gauge marks are opposite each other, and whether the adjustment for the height of the front sight is not impaired (this may be determined from the integrity of the drop of red lacquer inside the front sight cover).

d) **The functioning of the stock:** It should be checked in order to assure that the stock is tightly secured to the receiver, is steady and does not wobble significantly. The stock should also be checked for any cracks.

Inspection of the disassembled rifle

Before a disassembled rifle is inspected, all the components must be wiped dry. When the rifle is disassembled all the components must be carefully inspected in order to determine whether they are free of rust, whether they are soiled, crumbled off, battered, seized or excessively worn. Additionally, the **completeness of the rifle** should be verified.

Defective components which reveal fissures, rubbed-out spots, excessively worn active surfaces, stripped threads, loosened connections or those that are deformed and/or broken must be replaced. When inspecting the bore, it is necessary to lift the barrel together with the receiver up to the height of the eyes and turn the other end of the barrel toward the direction of the best light. While slowly rotating the barrel, it is necessary to carefully inspect the grooves of the bore, starting from the muzzle to the direction of the receiver. In order that the walls of the bore may be better seen along all the length of the barrel, it is necessary to vary the distance of one's eye from the muzzle.

When inspecting the bore, the following defects or troubles may be discovered:

- the remains of burnt powder or rust that appears as a dark tint. Rust or remainders of burnt powder undistinguishable by the eye may be found out by means of a white cloth which will show dark brown or black spots after wiping the bore. Grey spots in the bore that do not leave spots on the cloth after wiping the bore are not a fault;
- rust that appears like dots or small drops on some spots or all over the bore; shallow dark spots that remain after derusting;
- pits caused by rust are pits in the metal, visible to the eye;
- a copper coating which is caused by firing with projectiles provided with tombac jacket; they appear to the eye as a slight copper coat or bulge in the bore;
- scratches in the shape of dashes, many times with distinct prolapses of metal on the bore surface; rounding (wear, spalling of the chrome layer) of fields manifesting itself particularly on the left-hand edges of the fields; it occurs most often behind the cartridge chamber and near the muzzle;
- dark spots and an irregular surface behind the cartridge chamber (spalled chrome), which is a symptom of burning up the transition cone; - a bulge in the shape of a transversal dark ring; a rifle with a barrel damaged in this way must not be used for firing unless the rifle is checked.
- bending of the barrel that manifests itself as an irregular length of shade in the bore when rotating the barrel; battered spots on the rear face wall of the barrel, and scratches in the cartridge chamber.

When inspecting the receiver check:

- whether the guide bars, grooves and the active surfaces are scratched or rubbed by pressing; a glossy appearance to the surfaces of the projections on which the locking piece locks is permissible;
- whether the ejector is forced in, broken off or displaced in the grooves;
- whether the bolt catch is cracked, broken off or forced in;
- whether the safety catch holder is broken;
- whether the lacquer on the receiver is scratched off;
- whether the piston moves freely along the guide in the rear sight base.

When inspecting the bolt check:

a) Bolt carrier:

- whether the guide bars, grooves and active surfaces are scratched or rubbed by pressing; inspect if the face bearing surface is rammed down;
- whether chrome layer on the surfaces and edges is spalled or crumbled off

b) Bolt:

- whether the cartridge case bed and the opening for the firing pin are burnt off;
- whether there are fissures, pits or metallic deposits around the opening for the firing pin;
- whether the active surfaces are rubbed by pressing or rammed down;
- whether the end of the opening for the firing pin is flattened, i.e., whether the firing pin passes freely through the opening in the cartridge case bed; The bolt must shift out of or in the opening when the bolt carrier is overturned by its own weight or, at the most, when tapping slightly with the bolt carrier against the palm;
- whether the extractor claw is pressed with sufficient force in the bolt cartridge case bed;
- whether the extractor is clamped by the walls of its groove, i.e., whether it returns, after being deflected, energetically to the initial position;
- whether the extractor has fissures or whether the extractor claw is broken off or damaged in some other way.

c) **Locking piece:**

- whether it moves freely in the bearings of the bolt;
- whether the edges of locking lugs are battered or deformed in some other way; a glossy appearance of the active surfaces of the locking lugs and of the upper (glide-over) surface is permissible;
- whether the locking piece tilts over by its own weight into the locked position;
- whether the chrome layer on the surfaces or edges is spalled or crumbled off.

d) **Striker:**

- whether the nose of the striker head is worn out to excess;
- whether the striker passes freely through the opening in the bolt carrier.

When inspecting the **trigger mechanism check:**

- whether the trigger, disconnecter and sear pivot are free on their pins;
- whether the arm of the trigger mechanism feather is broken or bent and whether it is in the correct position under the sear;
- whether the sear is worn out to such an extent that it does not catch the striker reliably.

When inspecting the stock and **front handguards check:**

- whether the plastic parts are cracked, battered or deformed in some other way;
- whether the stock is loosened;
- whether the swivel on the stock is loosened or damaged.

2.4.2. Disassembling the rifle

The rifle is disassembled for the purpose of cleaning, preserving, for inspection and when replacing and/or repairing its parts.

There are two ways of disassembling the rifle:

- partial disassembling and
- complete disassembling.

Partial disassembling of the rifle is carried out by the owner for the purpose of common cleaning, preserving and inspecting.

Complete disassembling of the rifle is only carried out when replacing and repairing its parts at an authorized gunsmith workshop.

Disassembling and assembling too frequently harms the rifle as the wear on its components is accelerated. When disassembling and assembling the rifle, the following rules must be observed:

- Disassembling and assembling of the rifle should be carried out on a table or bench; when in the field, this should be carried out on a clean and dry sheet.
- Every time, before disassembling the rifle, the magazine should be taken out and make sure there is no cartridge in the cartridge chamber.
- When separating and assembling the components, handle them with care, do not use force as it could cause damage.

The rifle is designed so that all the components and mechanisms may be easily taken out from and inserted back into the rifle. For this reason no other tools should be used for taking out and inserting components and mechanisms of the rifle other than the front sight spanner, otherwise the components can be damaged.

For common maintenance of the rifle it is sufficient to remove the barrel guard, remove the return mechanism and take out the bolt. This allows access to the trigger mechanism. The rifle must be disassembled with its striker released.

Disassembling the rifle partially

The rifle should be disassembled in the below-mentioned sequence and extent (Fig. 26):



Fig. 26 **The Sa vz. 58 Bolt action partially disassembled**
1. Magazine, 2. Return mechanism, 3. Bolt, 4. Front guards

a) **Taking out the magazine** (Fig. 27): Hold the rifle by the grip panel with the right hand and grasp the front wall of the magazine with the left hand. Lean the left-hand thumb against the magazine catch and push it forward. Simultaneously, tilt the magazine forward in the direction of the barrel and pull it out from the receiver's magazine well.



Fig. 27 **Taking out the magazine**

b) **Removing the return mechanism** (Fig.27): With the left hand grasp the rifle from below by the receiver and by the thumb of the right hand, the palm of which leans against the top of the buttstock, depress the protruding end of pin 27. Then grasp the knurled head of the pin by the right-hand thumb and index finger and pull the pin out to the right until an audible click is heard.

Grasp the top of the buttstock with the right hand and lean the right-hand thumb against the rear wall of the receiver cover. Through forward pressure of the thumb and an upward shift, move the projection of the connecting locking plate of the return mechanism out from the receiver recess, and by pulling backwards, pull all the return mechanism out of the rifle.

c) **Taking out the bolt** (Fig. 29): Grasp the rifle with the left hand from below by the receiver. With the right hand using the cocking lever, pull the bolt carrier backwards to a stop. With the use of the cocking lever, take the bolt carrier out the receiver. As soon as the front part of the bolt is sufficiently lifted up above the receiver, push the right-hand fingers under the bolt; grasp the whole bolt carrier in the palm and take it out of the receiver.

Then take the bolt carrier by the left hand and with the right hand grasp the striker by its head and pull it out of the bolt carrier. While doing this, turn the striker slightly to the left until the projection of the bolt carrier passes through the cross groove to the neighboring through groove. Continue pulling the head of the striker, shift the striker completely out of the bolt carrier. The bolt is thereby released. Remove the locking piece from the bolt by tilting it upwards.



Fig. 28 Removing the return mechanism



Fig. 29 Taking out the bolt

2.4.3. Assembling the rifle

Assembling the partially disassembled rifle

The partially disassembled rifle should be assembled in the following order:

a) **Assemble the bolt:** Mount the locking piece with its joints into the bearings of the bolt. Insert the bolt in the recess in the bolt carrier near the bridge. Shift it forward in order to engage the

grooves in the carrier. Shift the striker in the bolt carrier so that the gauge mark on the striker is opposite the gauge mark on the rear wall of the bolt carrier. Then turn the striker by the whole length of the gauge mark to the right and shift it to a stop in the bolt carrier.

b) **Put the bolt carrier into the receiver:** grasp the assembled bolt carrier with the right hand so that the thumb leans against its rear face and the middle finger against its front face. Hold the rifle from below with the left hand by the receiver with the muzzle pointing slightly downwards. Insert the bolt carrier from above in the rear part of the receiver. Shift the inserted bolt carrier as far forward as possible. The striker will remain retained by the sear.

c) **Insert the return mechanism:** First of all, partially shift the striker spring in the cavity of the striker and then the return spring in the opening of the bolt carrier. Set the safety catch to "Fire" position and squeeze the trigger; the striker is then released by the sear and the return mechanism may be shifted forwards without any resistance.

Push the front part of the cover down in order to engage the grooves in the bolt carrier and by pushing forwards and downwards shift the projection of the base in the recess in the rear part of the receiver. Lock the return mechanism by shifting the pin of the receiver cover to the left until an audible click is heard.

2.5. MAINTENANCE

2.5.1. The main principles of rifle maintenance

One of the conditions for reliable functioning, accuracy of fire and long service life of the rifle is correct and timely cleaning and preserving as well as inspections. The rifle must always be kept in good order and clean.

Maintenance and care of the Sa vz. 58 Bolt Action is divided into

- daily care,
- and monthly care.

Daily care of the rifle should be carried out as soon as possible after shooting. The extent of the care is determined according to the needs which follow from the conditions of the shooting, from the weather conditions and the like.

After returning from shooting, the rifle should be partly disassembled and all the main parts completely cleaned. Over the following 3 to 4 days, check the rifle for rust. If, in doing this it still shows traces of impurities due to combustion products or rust, the cleaning procedure should be repeated.

Only after proper cleaning and wiping the rifle dry, can it be preserved with oil.

If the above-mentioned principles are observed, any inadequate deterioration of the technical condition of the rifle cannot occur.

Monthly care should be carried out even if the rifle is not fired within this time. At monthly checks, the rifle should be checked for any possible rust stains and sufficient oil preservation.

2.5.2. Cleaning and preserving agents

When cleaning and preserving the rifle, only specified cleaning and preserving agents of high quality should be used.

To clean the rifle only the following material should be used:

- Clean soft rags (coloured as well as white) to clean and preserve the components;
- Brass bore brush;
- Cotton patches;
- Horsehair brush (part of the rifle accessories);
- Toothbrush.

To preserve rifles the following should be used:

- High quality preservative to protect the metal parts of the rifle against corrosion;
- Gun oil to lubricate the friction surfaces of the rifle that are in use;

When cleaning and preserving rifle parts, it is necessary to proceed as follows:

a) The **bore** should be cleaned from the side of the muzzle. In order to do this, one must screw together cleaning rod and the handle. Then soak the brush in gun oil and run it through the bore several times continuously without any force and draw the cleaning rod seven to ten times along all the length of the bore.

Then remove the brush and put a dry pad extension onto the cleaning rod. Cleaning should be repeated several times until pad or piece of cloth shows no brown or black spots of the rust or combustion products.

When having drawn the cloth through for the last time there are no longer any traces of combustion products from powder (black or brown spots) or traces of rust, move on to cleaning the cartridge chamber.

After having finished cleaning the bore and the cartridge chamber, pull once more all the bore through and dry with clean pad extension or patch. Then carefully inspect the bore against the light while slowly rotating the barrel in your hands. It is especially necessary to carefully inspect the edges of the grooves near the muzzle and near the cartridge chamber, i.e. places from which impurities are the most difficult to remove. In order to check the condition of the cartridge chamber and that of the bore, a reflecting mirror can be used.

If the inspection demonstrates that the bore and the cartridge chamber are completely clean, immediately apply a slight layer of preservative. Pull the patch or pad extension saturated with preservative through the barrel bore. The patch must be of such a shape so as to pass easily through the bore. Draw the cleaning rod two times to three times continuously through all the length of the bore so that the preserving agent may fully adhere to the grooves and fields of the bore and to those of the cartridge chamber and form a thin continuous layer.

Excessively lubricated parts get quickly contaminated which is why it is necessary to apply only a fine layer of preserving agent by means of a greasy rag. When lubricating the recesses, grooves and gaps, it is necessary to roll the patch round a stick.

Preserving the bore with an oil gun protects it against corrosion for only a few days.

If the wiped dry bore is left without a preserving agent for more than an hour, it grows damp due to the effect of ambient air. The preserving agent must not be applied until the bore is re-wiped out dry with a clean dry cloth.

If rust is found during the cleaning, soften it with a cleaning solution, with kerosene or a preserving agent and then wipe it out with a clean patch. If the remains of powder combustion products and rust cannot be removed from the bore in the above-mentioned way, the rifle should be given to an authorized gunsmith.

b) The **receiver**, the **bolt** and the non-disassembled **trigger mechanism**, the **rear sight** and the **return** mechanism may be cleaned by means of wooden sticks wrapped with rags soaked in the cleaning gun oil; openings, grooves, cut-outs and recesses should be cleaned with pointed wood sticks. After cleaning, the components should be wiped dry with a clean rag and preserved with a light coat of preservative. Also of importance for checking, after cleaning the non-disassembled trigger mechanism, is whether the positions of the trigger mechanism components are correct, especially the positions of the arm of the trigger mechanism feather.

All components strongly soiled with powder combustion products should be immersed in the cleaning solution for a period of up to half-an-hour; the remainders of the cleaning solution must, however, be disposed of carefully. Cleaning gun oil or its emulsion should not be left in the bore.

c) The plastic parts, i.e., the **stock** and **upper** and **lower handguards** and **magazines** should be wiped with a moist cloth and then wiped dry with a clean dry cloth..

d) The **lacquered parts** of the rifle, such as the external surface of the barrel and receiver, that of the bolt carrier, trigger guard and return mechanism cover should not be preserved; they should be wiped with an oily cloth and then wiped with a clean dry cloth.

After having applied the preserving agent, the rifle should be assembled. If the preserving agent gets wiped off at some points during assembly of the rifle, it will be necessary to restore the preserving agent layer.

2.6. Repairs

2.6.1. Repairing the Rifle

The rifle owner should only carry out minor repairs within the scope of repairs of malfunctions described in the Troubleshooting section of this manual (Part II – Chapter 2).

Any other repairs should be performed by an authorized gunsmith only. Non compliance with this rule may result in serious damage to the rifle or the owner's health and may also void the warranty provided by manufacturer.

3. Technical parameters

Technical parameters of Sa vz. 58 Bolt Action RIFLE, cal. 5.56 x 45 mm (.223 Rem)	
Caliber	.223 Rem (5.56 x 45 mm)
Muzzle velocity	890 – 910 m/s
Number of grooves	4
Twist of the rifling	1:7
Overall length of rifle	905 mm
Barrel length	410 mm
Length of sight line	375 mm
With of rifle	59 mm
Height of rifle with magazine	170 mm
Practical rate of fire	40 shots /min.
Maximal range of fire	1 800 m
Lethal effect of projectile	1,400 m
Weight of rifle (without magazine)	3.07 kg
Weight of rifle with loaded magazine	3.58 kg
Weight of empty magazine	0.15 kg
Trigger pull	2.5 to 2.7 kg (24.5 to 26.5 N)

Technical parameters of Sa vz. 58 Bolt Action porter CARBINE 5.56 x 45 mm (.223 Rem)	
Caliber	.223 Rem (5.56 x 45 mm)
Muzzle velocity	790 to 830 m/s
Number of grooves	4
Twist of the rifling	1:7
Overall length of rifle, with stock unfolded	755 mm
Overall length of rifle, with stock folded	545 mm
Barrel length	300 mm
Length of sight line	265 mm
Width of rifle	59 mm
Height of rifle with magazine	170 mm
Practical rate of fire	40 shots /min.
Maximum range of fire	1,800 m
Lethal effects of projectile up to	1,400 m
Weight of rifle (without magazine)	2.97 kg
Weight of rifle with loaded magazine	3.48 kg
Weight of empty magazine	0.15 kg
Trigger pull	2.5 to 2.7 kg (24.5 to 26.5 N)

Technical parameters of Sa vz. 58 Bolt Action COMPACT, cal. 5,56 x 45 (.223 Rem)	
Caliber	.223 Rem (5.56 x 45 mm)
Muzzle velocity	675 to 685 m/s
Number of grooves	4
Twist of the rifling	1:7
Overall length of rifle, with stock unfolded	645 mm
Overall length of rifle, with stock folded	435 mm
Barrel length	190 mm
Length of sight line	155 mm
Width of rifle	59 mm
Height of rifle with magazine	170 mm
Practical rate of fire	40 shots /min.
Maximum range of fire	1,100 m
Lethal effect of projectile	1,100 m
Weight of rifle (without magazine)	2.75 kg
Weight of rifle with loaded magazine	3.26 kg
Weight of empty magazine	0.15 kg
Trigger pull	2.5 to 2.7 kg (24.5 to 26.5 N)

Technical parameters of Sa vz. 58 Bolt Action RIFLE 7.62 x 39 mm	
Caliber	7.62 x 39 mm
Muzzle velocity	690 – 700 m/s
Number of grooves	4
Twist of the rifling	240 mm
Overall length of rifle	905 mm
Barrel length	410 mm or 390 mm
Length of sight line	375 mm (355 mm with the 390 mm barrel)
Width of rifle	59 mm
Height of rifle with magazine	170 mm
Practical rate of fire	40 shots/min.
Maximum range of fire	2 800 m
Lethal effect of projectile	2 800 m
Weight of rifle (without magazine)	3.10 kg
Weight of rifle with loaded magazine	3.84 kg
Weight of empty magazine	0.19 kg
Trigger pull	2.5 to 2.7 kg (24.5 to 26.5 N)

Technical parameters Sa vz. 58 Bolt Action CARBINE 7,62 x 39 mm	
Caliber	7.62 x 39 mm
Muzzle velocity	670–700 m/s
Number of grooves	4
Twist of the rifling	240 mm
Overall length of rifle with stock unfolded	755 mm
Overall length of rifle with stock folded	545 mm
Barrel length	300 mm
Length of sight line	265 mm
Width of rifle	59 mm
Height of rifle with magazine	170 mm
Practical rate of fire	40 shots/min.
Maximum range of fire	2,500 m
Lethal effect of projectile	2,500 m
Weight of rifle (without magazine)	2.97 kg
Weight of rifle with loaded magazine	3.65 kg
Weight of empty magazine	0.19 kg
Trigger pull	2.5 to 2.7 kg (24.5 to 26.5 N)

Technical parameters Sa vz. 58 Bolt Action COMPACT 7.62 x 39 mm	
Caliber	7.62 x 39 mm
Muzzle velocity	560 to 570 m/s
Number of grooves	4
Twist of the rifling	240 mm
Overall length of rifle with stock unfolded	645 mm
Overall length of rifle with stock folded	435 mm
Barrel length	190 mm
Length of sight line	155 mm
Width of rifle	59 mm
Height of rifle with magazine	170 mm
Practical rate of fire	40 shots/min.
Maximum range of fire	1,800 m
Lethal effect of projectile	1,800 m
Weight of rifle (without magazine)	2.75 kg
Weight of rifle with loaded magazine	3.43 kg
Weight of empty magazine	0.19 kg
Trigger pull	2.5 to 2.7 kg (24.5 to 26.5 N)

4. List of components

List of parts of Sa vz. 58 Sporter, cal. .223 Rem; .222 Rem; 7.62 x 39 mm

58-1-001	Barrel, cal. 7.62 x 39 mm	58-1-033	Extractor spring
58-2-001	Barrel, cal. 5.56 x 45 mm	58-1-034	Extractor stay
58-5-001	Barrel, cal. .222 Rem	58-1-035	Bolt carrier
58-1-011	Front sight	58-1-036	Locking piece
58-1-111	Front sight nut	58-1-037	Striker
58-1-012	Front sight base	58-1-038	Return mechanism base
58-1-121	Front sight base pin	58-1-381	Receiver cover
58-1-014	Gas adapter	58-1-382	Striker spring
58-1-015	Front swivel	58-1-383	Striker spring guide
58-1-016	Lower handguard hoop	58-1-384	Return spring
58-1-017	Barrel pin	58-1-385	Return spring guide
58-1-018	Muzzle break	58-1-386	Return spring locking block
58-1-019	Muzzle thread cover	58-1-004	Trigger
58-1-191	Muzzle nut safety pin	58-1-041	Trigger pin
58-1-192	Muzzle nut safety pin spring	58-1-042	Disconnecter
58-1-002	Receiver, 7.62	58-1-043	Disconnecter spring
58-2-002	Receiver, 5.56 and .222 Rem	58-1-044	Disconnecter pin
58-1-021	Rear sight	58-1-045	Sear
58-1-211	Slide	58-1-046	Sear pin
58-1-212	Rear sight plunger	58-1-047	Trigger mechanism feather
58-1-213	Rear sight plunger spring	58-1-048	Safety catch
58-1-214	Rear sight feather	58-1-049	Safety catch holder
58-1-022	Ejector	58-1-005S	Sporter stock – frame type
58-1-023	Bolt catch	58-1-005P	Polymer fixed stock
58-1-231	Bolt catch spring	58-1-005PF	Polymer folding stock
58-1-024	Magazine catch	58-1-005F	Folding stock
58-1-241	Magazine catch pin	58-1-005T	Telescopic stock
58-1-242	Magazine catch spring	58-1-051	Rear swivel
58-1-243	Magazine catch pin safety pin	58-1-051F	Folding hinge
58-1-025	Receiver cover pin	58-1-511	Rear swivel fixture
58-1-026	Receiver cover pin safety pin	58-1-511F	Folding stock hinge
58-1-027	Safety stop	58-1-512	Rear swivel base
58-1-028	Trigger guard	58-1-513	Rear swivel insert
58-1-003	Bolt, cal. 7.62 x 39 mm	58-1-519T	Telescopic stock adapter
58-2-003	Bolt, cal. 5.56 x 45 mm and .222 Rem	58-1-519AR	AR-15/M4 stock adapter
58-1-031	Firing pin, cal. 7.62 x 39 mm	58-1-052S	Sporter stock screw
58-2-031	Firing pin, cal. 5.56 x 45 mm and .222 Rem	58-1-052F	Folding stock screw
58-1-031	Extractor, 7.62	58-1-053E	Ergonomic grip
58-2-032	Extractor, 5.56 and .222 Rem	58-1-531S	Sporter grip screw
		58-1-531E	Ergonomic grip screw

58-1-532S	Sporter grip screw washer
58-1-054	Grip screw nut
58-1-055P	Upper handguard
58-1-055CP	Compact upper handguard
58-1-055R	Upper handguard with rails
58-1-551	Upper handguard base
58-1-552	Upper handguard pin
58-1-553	Upper handguard pin pawl
58-1-554	Upper handguard pin pawl spring
58-1-555	Upper handguard flat spring
58-1-055R+056R	Polymer picatinny handguard set
58-1-056P	Lower handguard
58-1-056CP	Compact lower handguard
58-1-056R	Lower handguard with rails
58-1-561	Lower handguard pin
58-1-006H	Magazine body, cal. 7.62 mm
58-2-006H	Magazine body, cal. 5.56 mm
58-1-061H	Magazine follower, cal. 7.62 mm
58-2-061H	Magazine follower, cal. 5.56 mm
58-1-062H	Magazine spring, cal. 7.62 mm
58-2-062H	Magazine spring, cal. 5.56 mm
58-1-063H	Magazine floor plate safety, cal. 7.62mm
58-2-063H	Magazine floor plate safety, cal. 5.56mm
58-1-064H	Magazine floor plate, cal. 7.62 mm
58-2-064H	Magazine floor plate, cal. 5.56 mm
58-1-008	Sling
58-1-009	Cleaning kit bag, cal. 7.62 mm
58-2-009	Cleaning kit bag, cal. 5.56 mm
58-1-091	Cleaning rod, cal. 7.62 mm
58-2-091	Cleaning rod I for cal. 5.56 mm
58-1-092	Patch holder for cal. 7.62mm
58-2-092	Cleaning rod II for cal. 5.56 mm
58-1-093	Brush for cal. 7.62 mm
58-2-093	Brush for cal. 5.56 mm
58-1-094	Oil can
58-1-941	Oil can plug
58-1-942	Oil can seal
58-1-095	Needle
58-1-096	Cheek piece
58-1-961	Cheek piece pad

Czech Small Arms, s.r.o.



Jablůnka 651 | 756 23 Jablůnka | Czech Republic

cell: +420 605 945 532 | fax: +420 571 452 201

info@csa.co.cz | www.csa.co.cz